

Series CA6 Contactors

The modern contactor for demanding applications from 75 to 600HP (@460V) - 100 to 700HP (@ 575V)



Sprecher + Schuh's CA6 contactor line combines the simple function of our popular CA7 series with the rugged performance demanded in this middle horsepower range. On average these contactors are 50% smaller than traditional contactors in this size class.

A broad selection for middle horsepower applications

The CA6 range consists of nine contactors in three frame sizes covering motors from 75 to 600HP at 460V and from 100 to 700HP at 575V. This line is ideally suited for demanding applications such as steel mills, rock quarries, mines or for any middle horsepower application where a sturdy, durable contactor is needed.

Rugged and reliable

CA6 contactors conform to UL508, IEC 60947 and can be operated at rated voltages up to 600V (UL) and 1000V (IEC). High thermal and switching capacities guarantee reliable operation and long life. CA6 contactors are listed in CSA Certified Elevator Equipment for heavy duty use in elevators, refrigerators and heating installations in Canada.

Arc quenching extends contact life

All CA6 contactors are designed with sophisticated arc quenching techniques that extinguish damaging breaking arcs quickly. This is accomplished by guiding the arc away from the contacts and into "arc chambers" which are built-in to every CA6 cover.

Safety first

CA6 arc chambers are completely enclosed (without arc exhaust vents), offering the best protection against hot arcing gases. A large safety distance in front of the contactor is unnecessary. CA6 contactors are also designed so that operation is impossible if the arc chambers are removed. Conversely, once the contactor is energized, the arc chambers cannot be removed.

When used with terminal covers or HB Touch-Safe Lugs, CA6 contactors meet international standards for touch-safe design.

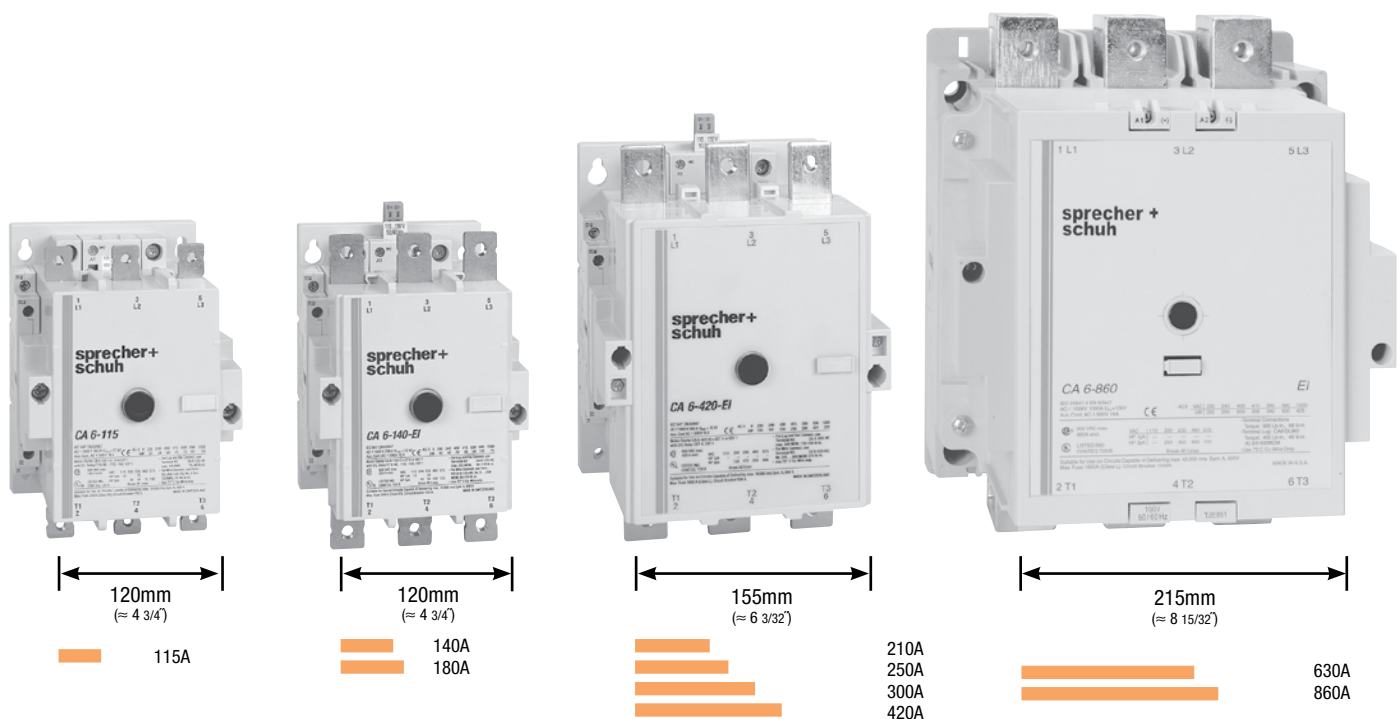

Electronic coils offer many advantages

Behind the attractive outward appearance of the CA6 contactor are advanced engineering solutions that offer convenience and savings. The entire line can be equipped with an electronically controlled coil that reduces pick-up currents by 60% on average. Holding current is also reduced.

Comparison of pick-up and holding current [VA]

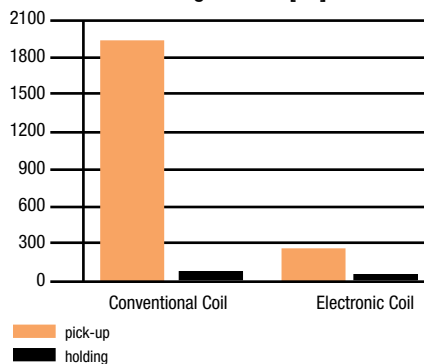

Other advantages of the CA6 electronic coil include:

- Direct connection to a PLC
- Overvoltage protection and suppression circuits (eliminating interference from the coil) are standard

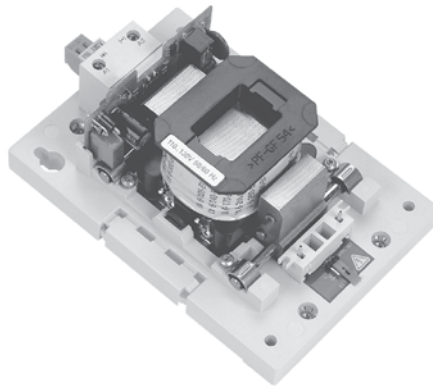

CA6 "EI" electronic coils offer many unique advantages over conventional types

- Smooth, even operation over the entire voltage range minimizes the possibility of contact bounce
- No safeguards are necessary to bridge brief supply interruptions
- Precisely defined pick-up and drop-out voltages, eliminate the possibility of chattering
- Electronic coils operate over a much broader voltage range, providing flexibility in applications and lower costs due to reduced inventory

Two user-selectable modes

CA6 contactors with electronic coils operate in either the "E" mode for normal operation or the "EI" mode for interfacing directly with a Programmable Logic Controller (PLC) or other low level signal source (13...30.2 VDC). The coil is set in the "E" mode from the factory, offering all of the functions and advantages of an electronic coil with the exception of electronic interface. An orange "jumper" located on the bottom of the contactor can be quickly changed if interface from a PLC is desired. A detailed technical explanation of CA6-EI coils along with connection diagrams can be found in the Technical Section.

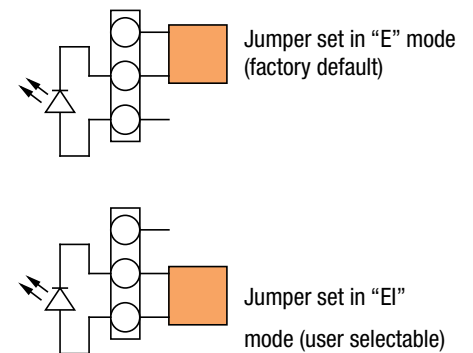

The entire CA6 line is modularly designed for easy inspection, coil change and contact replacement. Maintenance can be performed from the front so that mounting requires no additional space. Even with the installation of mechanical interlocks and auxiliary contact blocks, the units can be flush mounted side by side, saving panel space.

- 1 CA6-115-EI Contactor
- 2 CA6-140-EI Contactor
- 3 Main Terminal Set
- 4 Lug set
- 5 Mechanical Interlock
- 6 Aux. Contact Block
- 7 Aux. Contact Block
- 8 Aux. Contact Block
- 9 Aux. Contact Block
- 10 Terminal Cover
- 11 Surge Suppressor

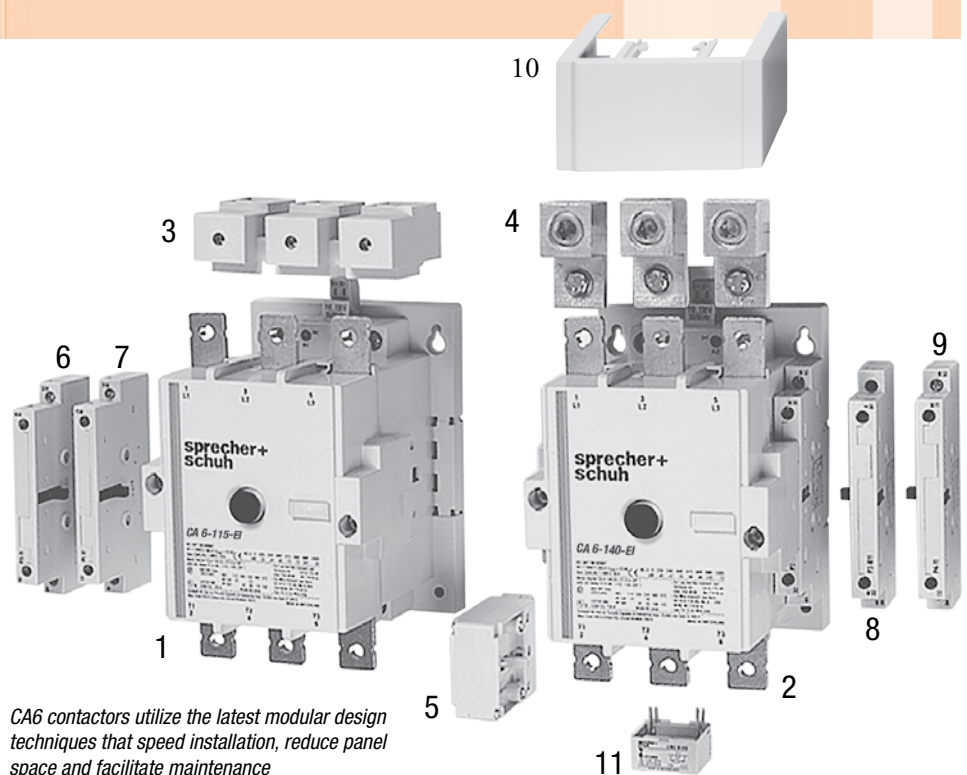

CA6 contactors utilize the latest modular design techniques that speed installation, reduce panel space and facilitate maintenance

Non-Reversing, Three Pole Contactors With AC Coil, Series CA6 (Open type only) ①③

I _e [A]		Ratings for Switching AC Motors (AC2 / AC3)										Auxiliary Contacts per Contactor		Open Type
		kW (50 Hz)				UL/CSA HP (60 Hz)								
		230V	400V/ 415V	500V	690V	1 Ø		3 Ø						
115V	230V					200V	230V	460V	575V	NO	NC			
AC-3	AC-1	230V	400V/ 415V	500V	690V	115V	230V	200V	230V	460V	575V	NO	NC	Catalog Number ①③
115	250	37	64/66	80	111	10	25	40	40	75	100	1	1	CA6-115-11-*
140	250	45	78/82	80 ④	111	15	30	40	50	100	125	1	1	CA6-140-11-*
180	250	57	101/105	98 ④	135 ④	~	40	50	60	150	150	1	1	CA6-180-11-*
210	350	67	118/122	147	205	~	50	60	75	150	200	1	1	CA6-210-EI-11-*
250	350	80	140/145	177	250	~	~	75	100	200	250	1	1	CA6-250-EI-11-*
300	450	97	170/176	213	293	~	~	100	125	250	300	1	1	CA6-300-EI-11-*
420	540	135	238/250	298	424	~	~	150	175	350	400	1	1	CA6-420-EI-11-*
630	800	200	355	450	500	~	~	200	250	500	600	1	1	CA6-630-EI-11-*
860	1000	250	500	560	~	~	~	250	300	600	700	1	1	CA6-860-EI-11-*



CA6-140-EI contactor



CA6-420-EI contactor

Note: CA6 open-type contactors include terminal bolts. If lugs are required, see page A99 for ordering information.

Coil Codes ②

CA6-115 /140 /180		
AC Coil Code	Voltage Range	
	50 Hz	60 Hz
24	~	24V
120B	110V	120V
208	~	208V
240B	220-230V	260V
277	240V	277V
380	380-400V	440V
480	415V	480V
575	500V	575V

CA6-115-EI ...CA6-420-EI ①		
AC Coil Code	Voltage Range	
	50 Hz / 60 Hz	
24 ⑤	24V	
120 ⑥	110-130V	
220W	208-277V	
460W	380-500V	

CA6-630-EI ...CA6-860-EI ①		
AC Coil Code	Voltage Range	
	50 Hz / 60 Hz	
120	110-130V ⑥	
208W	200-220V	
240W	230-250V ⑥	
277	277V	
480	440-480V	

CA6 “EI” coils are electronically controlled coils with the following characteristics:

- Ability to connect directly to a low level signal source such as a PLC (13-30 VDC at 15mA max.)
- Very low pull-in and holding current for contactors in this size class
- Threshold voltages for pull-in and drop-out are very precisely defined, eliminating “chattering”
- Supply voltage dips are bridged without extra equipment
- “EI” coils cover a much wider voltage range with only one coil

Ordering Instructions

Specify Catalog Number	
Replace (*) with Coil Code	See Coil Codes on this page

- ① “EI” designates contactor with Electronic Interface coil.
- ② Other voltages available, see page A104-A105. *Non-standard coil voltages not listed here must be ordered and installed separately as renewal parts.*
- ③ For CSA Elevator duty rating, consult Technical Information on page A109.
- ④ Ratings are higher for contactors with electronic coil:

CA6-140-EI-11-*	CA6-180-EI-11-*
500V = 98 kW	500V = 126 kW
690V = 135 kW	690V = 176 kW
- ⑤ 24 VAC Coil is not available for CA6-420-EI.
- ⑥ Coil is rated AC/DC.

Non-Reversing, Three Pole Contactors With DC Coil, Series CA6 (Open type only) ①③

I _e [A]		Ratings for Switching AC Motors (AC2 / AC3)										Auxiliary Contacts per Contactor		Open Type
		kW (50 Hz)				UL/CSA HP (60 Hz)								
		230V		400V/415V	500V	690V	1 Ø		3 Ø					
AC-3	AC-1	230V	400V/415V	500V	690V	115V	230V	200V	230V	460V	575V	NO	NC	Catalog Number ①③
115	250	37	64/66	80	111	10	25	40	40	75	100	1	1	CA6-115-L22-* CA6-115-EI-11-*
140	250	45	78/82	80 ④	111	15	30	40	50	100	125	1	1	CA6-140-L22-* CA6-140-EI-11-*
180	250	57	101/105	98 ④	135 ④	~	40	50	60	150	150	1	1	CA6-180-L22-* CA6-180-EI-11-*
210	350	67	118/122	147	205	~	50	60	75	150	200	1	1	CA6-210-EI-11-*
250	350	80	140/145	177	250	~	~	75	100	200	250	1	1	CA6-250-EI-11-*
300	450	97	170/176	213	293	~	~	100	125	250	300	1	1	CA6-300-EI-11-*
420	540	135	238/250	298	424	~	~	150	175	350	400	1	1	CA6-420-EI-11-*
630	800	200	355	450	500	~	~	200	250	500	600	1	1	CA6-630-EI-11-*
860	1000	250	500	560	~	~	~	250	300	600	700	1	1	CA6-860-EI-11-*



CA6-140-EI contactor with DC coil



CA6-420-EI contactor with DC coil

Note: CA6 open-type contactors include terminal bolts. If lugs are required, see page A99 for ordering information.

Coil Codes ②

CA6-115 / 140 / 180	
DC Coil Code	Voltage Range
24D	24V
110D	110V
220D	220V

Note: Conventional DC coils have high current pick-up winding and low current “seal-in” winding wired in parallel. The pick-up winding is taken out of the circuit after the armature pulls in. Price includes two winding coil and an L11 block including one NC late break auxiliary contact mounted on the right side. See page A120 for functional schematic and see page C105 for a starter wiring diagram.

CA6-115-EI...CA6-420-EI ①	
DC Coil Code	Voltage Range
24D ⑤	24V
120D	110-130V
220D	200-255V

CA6-630...CA6-860-EI ①	
DC Coil Code	Voltage Range
120	110-130V ⑤
240W	200-255V ⑤

CA6 “EI” coils are electronically controlled coils with the following characteristics:

- Ability to connect directly to a low level signal source such as a PLC (13-30 VDC at 15mA max.)
- Very low pull-in and holding current for contactors in this size class
- Threshold voltages for pull-in and drop-out are very precisely defined, eliminating “chattering”
- Supply voltage dips are bridged without extra equipment
- “EI” coils cover a much wider voltage range with only one coil

Ordering Instructions

Specify Catalog Number	
Replace (*) with Coil Code	See Coil Codes on this page

- ① “-EI” designates contactor with Electronic Interface coil.
- ② Other voltages available, see page A104-A105. *Non-standard coil voltages not listed here must be ordered and installed separately as renewal parts.*
- ③ For CSA Elevator duty rating, consult Technical Information on page A109.
- ④ Ratings are higher for contactors with electronic coil:
CA6-140-EI-11-* CA6-180-EI-11-*
500V = 98 kW 500V = 126 kW
690V = 135 kW 690V = 176 kW
- ⑤ 24V DC Coil not available for CA6-420-EI. Customers selecting 24V DC Coils should consider the “EI” functionality of the CA6 (see pages A119-A120).
- ⑥ Coil is rated AC/DC.

Reversing, Three Pole Contactors With AC Coil, Series CA6 (Open type only) ⑥

I _e [A]		Ratings for Switching AC Motors (AC2 / AC3)										Auxiliary Contacts per Contactor		Open Type
		kW (50 Hz)					UL/CSA HP (60 Hz)							
		AC-3	AC-1	230V	400V/415V		500V	690V	1 Ø		3 Ø			
											115V	230V	200V	230V
115	250	37	64/66	80	111	10	25	40	40	75	100	1	1	CAU6-115-22-* CAU6-115-EI-22-*
140	250	45	78/82	80 ⑦	111	15	30	40	50	100	125	1	1	CAU6-140-22-* CAU6-140-EI-22-*
180	250	57	101/105	98 ⑦	135 ⑦	~	40	50	60	150	150	1	1	CAU6-180-22-* CAU6-180-EI-22-*
210	350	67	118/122	147	205	~	50	60	75	150	200	1	1	CAU6-210-EI-22-*
250	350	80	140/145	177	250	~	~	75	100	200	250	1	1	CAU6-250-EI-22-*
300	450	97	170/176	213	293	~	~	100	125	250	300	1	1	CAU6-300-EI-22-*
420	540	135	238/250	298	424	~	~	150	175	350	400	1	1	CAU6-420-EI-22-*
630	800	200	355	450	500	~	~	200	250	500	600	1	1	CAU6-630-EI-22-*
860	1000	250	500	560	~	~	~	250	300	600	700	1	1	CAU6-860-EI-22-*

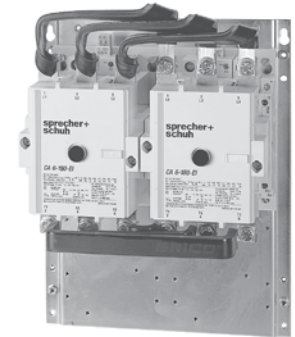

CAU6-180 reversing contactor

Includes:

- Mechanical and electrical Interlock ④
- Reversing power wiring (using Power Wiring Kit Cat.# CA6-...VL[T]) ①
- Mounting plate
- Control wiring available; see footnote ②

Note: CA6 open-type contactors include terminal bolts. If lugs are required, see page A99 for ordering information.

Coil Codes ②

CA6-115 / 140 180		
AC Coil Code	Voltage Range	
	50 Hz	60 Hz
24	~	24V
120B	110V	120V
208	~	208V
240B	220-230V	260V
277	240V	277V
380	380-400V	440V
480	415V	480V
575	500V	575V

CA6-115-EI ...CA6-420-EI ①	
AC Coil Code	Voltage Range
	50 Hz / 60 Hz
24 ③	24V
120	110-130V
220W	208-277V
460W	380-500V

CA6-630-EI ...CA6-860-EI ①	
AC Coil Code	Voltage Range
	50 Hz / 60 Hz
120	110-130V ③
208W	200-220V
240W	230-250V ③
277	277V
480	440-480V

CA6 “EI” coils are electronically controlled coils with the following characteristics:

- Ability to connect directly to a low level signal source such as a PLC (13-30 VDC at 15mA max.)
- Very low pull-in and holding current for contactors in this size class
- Threshold voltages for pull-in and drop-out are very precisely defined, eliminating “chattering”
- Supply voltage dips are bridged without extra equipment
- “EI” coils cover a much wider voltage range with only one coil

- ① For Reversing Contactors *without* power wiring add suffix “-LW” to catalog number and deduct \$175 for CA6-115...180 and \$360 for CA6-210-EI...860-EI. Example: CAU6-115-22-* becomes CAU6-115-22-***-LW**. Control wiring is not included.
- ② For control wiring, add suffix **-CW** to catalog number and add \$20. Example: CAU6-115-22-* becomes CAU6-115-22-***-CW**.
- ③ “-EI” designates contactor with Electronic Interface coil.
- ④ One NC auxiliary contact on each contactor is used for electrical interlocking.
- ⑤ Other voltages available, see page A104-A105. *Non-standard coil voltages not listed here must be ordered and installed separately as renewal parts.*
- ⑥ For CSA Elevator duty rating, consult Technical Information on page A109.
- ⑦ Ratings are higher for contactors with electronic coil:







CA6-140-EI-11-*	CA6-180-EI-11-*
500V = 98 kW	500V = 126 kW
690V = 135 kW	690V = 176 kW

- ⑧ 24 VAC Coil is not available for CA6-420-EI.
- ⑨ Coil is rated AC/DC.

Ordering Instructions

Specify Catalog Number	
Replace (*) with Coil Code	See Coil Codes on this page



Auxiliary Contact Blocks, 2 Pole

Auxiliary Contact Blocks	NO	NC	Contact Arrangement	Mounting Position	Catalog Number
	1	1		Inside left or right	CA6-S1-11
	1	1		Outside left or right	CA6-S2-11
	1	1 LB		Inside left or right	CA6-S1-L11
	2	0		Inside left or right	CA6-S1-20
	2	0		Outside left or right	CA6-S2-20
	Form C Electronic Compatible				Inside left or right

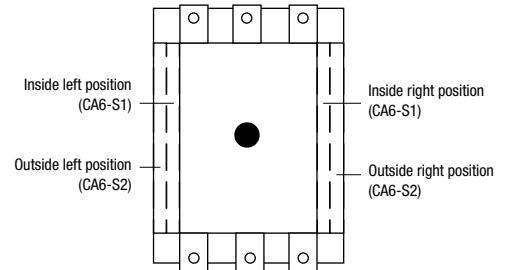
NOTE: Up to four auxiliary contact blocks (8 poles) may be mounted on the side of the CA6 contactor. One auxiliary contact block (1 NO + 1 NC) is mounted at the factory. New style CA6-95...140 contactors with conventional DC coils have an “-L11” mounted to right side and an “-11” mounted to left side at the factory.



Miscellaneous Accessories

Accessory	Description	For use with...	Catalog Number
  CM6 CM6-D00	Mechanical Interlock- ● No built-in auxiliaries	Interlocks CA6 contactors	CM6
		Interlocks CA6 contactors	CM6-D00
 CM6-D02	Mechanical / Electrical Interlock - ● Two built-in N.C. auxiliaries	Interlocks CA6 to CA7-60...85 contactors	CM6-C02
		Interlocks CA6 contactors	CM6-D02

① Electronic compatible auxiliary contacts function through the use of an internal micro-switch and have the following ratings:

IEC 947 Data:

AC-1	250V	0.1A
AC-15/DC-13 min.	3...125V	1...100mA

UL 508, CSA 22.2 Data:

250VAC max.	0.1A
Minimum Switching	17V 5mA

CA6 Electronic Coils (CA6-95-EI...CA6-860-EI)

CA6-EI contactors are supplied with an electronically controlled mechanism, which has an integrated electronic interface that consists of the following main parts:

- The coil bobbin rated for the control voltage.
- A printed circuit board with components for control and interface functions which is matched to the coil and rated for the control voltage.
- An interconnecting printed circuit board with coil terminals, which is located in the contactor base.
- R/C transient surge suppressors which are installed on the printed circuit board.

The CA6-EI coil bobbin and printed circuit board are a matched set; therefore, both must be changed when replacing the coil or changing out the coil to a different voltage. All replacement coils include both the coil bobbin and printed circuit board.

Commissioning

The CA6-EI contactor is operated in either the “E” mode (normal operation) or the “EI” mode (electronic interface operation) and is programmed by an orange “jumper” located on the bottom side of the contactor (opposite the coil terminals). This orange jumper is directly underneath main terminal T2 and is exposed by removing the small plastic cover that shields the mating space for the CRC/CRV protection element.

Electronic Operation – “E” Mode

For the “E” mode (factory default setting), the contactor is connected and controlled using terminals A1 & A2 in the same manner as a traditional contactor with an electromechanical coil mechanism. The contactor is programmed from the factory in the “E” mode by means of the orange jumper in the position as shown in Detail A. The “E” mode (or electronic mode) provides electronic control of the coil mechanism, but does not allow coil energizing from a low level signal source such as a PLC.

Electronic Interface Operation – “EI” Mode

For the “EI” mode, or optional electronic interface setting, the contactor can be switched from a PLC or other low-level signal source (13...30.2 VDC) without the need for an interposing relay. The contactor is programmed for the “EI” mode by moving the orange jumper to the position as shown in Detail B.

In the “EI” mode, the control voltage (VAC or VDC) must be permanently switched on to terminals A1 & A2 while in operation. The control signal from the PLC or other low-level signal source must be applied to terminals B1 & B2 (orange terminals) of the electronic interface in order to energize the contactor. The current burden of the interface is 15mA maximum.

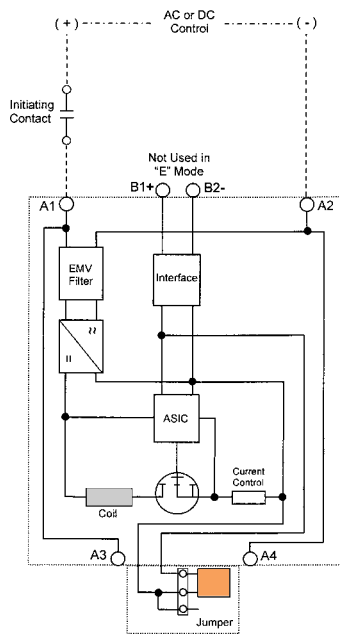

“E” Mode or Normal Operation
Detail-A

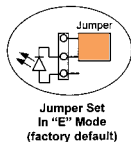

Jumper Set
In “E” Mode
(factory default)

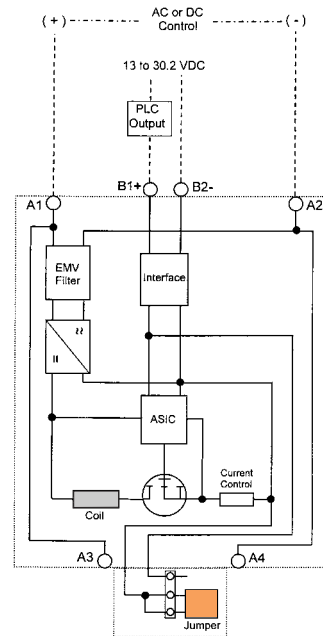

“EI” Mode or Interface Operation
Detail-B

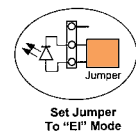

Set Jumper
To “EI” Mode

CA6 Conventional DC Coil (CA6-95...CA6-180)

Conventional 3-lead DC Coil (Old Style)

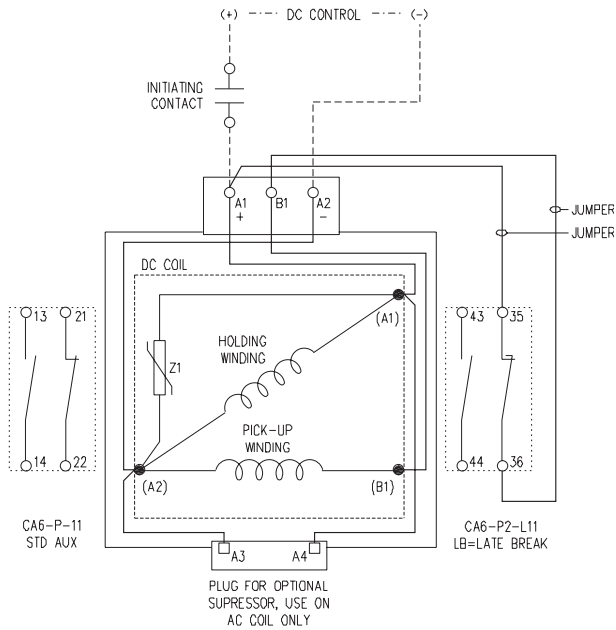

Conventional 3-lead DC Coil (New Style)

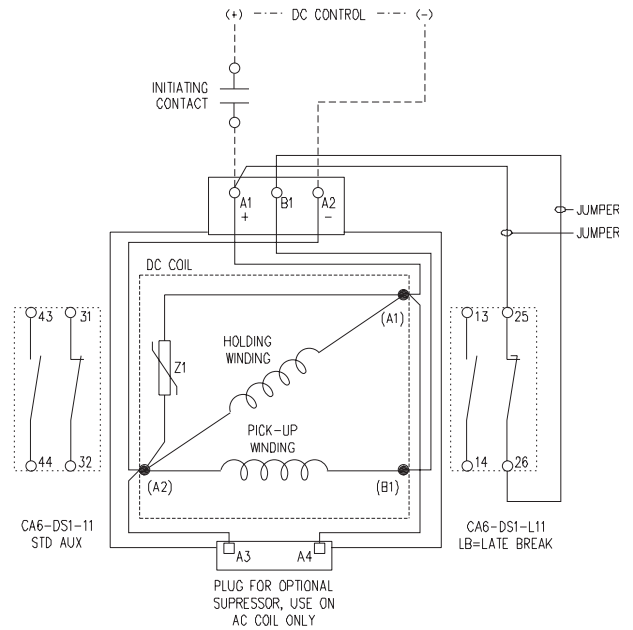

Notes

- 1) The CA6 conventional DC coil has dual windings with three leads brought out. One winding is the "pick-up" winding and the other is the "holding" winding. The coil also has a built-in voltage limiting varistor (Z1).
- 2) The pick-up winding has low resistance while the holding winding has a higher resistance.
- 3) When the control circuit is energized, the contactor "pulls-in" through the lower resistance pick-up winding and the NC late break auxiliary contact. After the contactor seals in, the late break contact opens and the contactor is held in through the holding winding.
- 4) The pick-up winding is not designed for continuous operation and must be disconnected by the "late break" contact immediately after the contactor pulls-in.

Series CA6 & Series CAU6 (Contactors & Reversing Contactors)

Dimensions are in millimeters (inches). Dimensions not intended for manufacturing purposes.

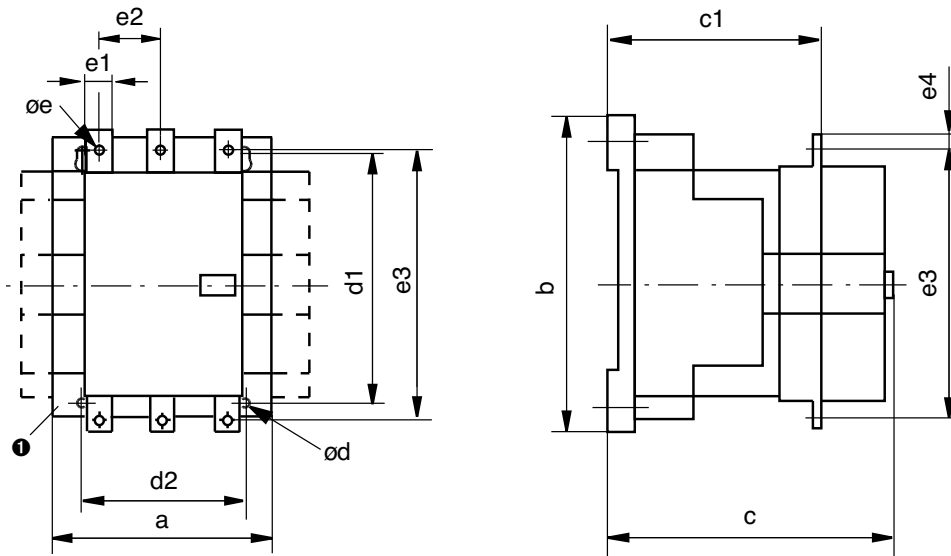

Catalog Number	a	b	c	c1	d	d1	d2	e	e1	e2	e3	e4
CA6-115(-EI); CA6-140(-EI); CA(N)6-180(-EI);	120 (4-3/4)	170 (6-11/16)	156 (6-1/8)	110.5 (4-11/32)	5.2 (7/32)	145 (5-11/16)	100 (3-15/16)	M8	20 (13/16)	39 (1-35/64)	160 (6-19/64)	10 (25/64)
CA6-210-EI...CA6-250-EI CA(N)6-300(-EI); CA6-420-EI	155 (6-1/8)	222 (8-23/32)	180 (7-3/32)	110.5 (4-11/32)	6.5 (9/32)	180 (7-3/32)	130 (5-1/8)	M10	25 (1)	48 (1-7/8)	193 (7-19/32)	12.5 (31/64)
CA6-630-EI...CA6-860-EI	255 (10-3/64)	337 (11-1/4)	265 (10-7/16)	110.5 (4-11/32)	10 (25/64)	230 (9-1/16)	225 (8-55/64)	M12	40 (1-37/64)	70 (2-3/4)	291 (11-29/64)	22 (55/64)

Reversing Contactors & Accessories (+...)

Contactor with...	CA6...	Dimension [mm]	Dimension [inches]
- auxiliary contact block ❶	+ S1 + S2	a a + 13.5 mm each	a a + 9/32 each
- reversing w/mechanical interlock		a + a	a + a
- main terminal set	HB2 HB3	b + 7mm each b + 8.5mm each	b + 19/64 each b + 11/32 each
- label holder		c + 5mm	c + 3/16

Mounting Position

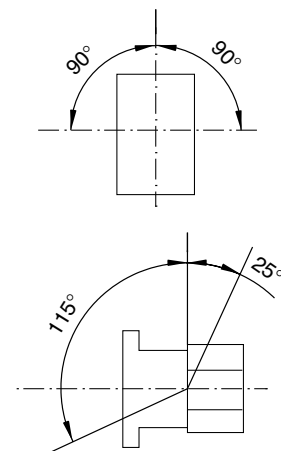

❶ No change of base dimensions with 1 or 2 auxiliary contact blocks (S1 or S2).
Each dimension increased by 13.5 mm to the "a" dimensions on the right hand side.

Replacement Contactors Cross Reference, Series CA1 to Series CA6 (Open Type Only) ❶

I _e [A] ❶		Ratings for Switching AC Motors (AC2 / AC3 / AC4)										Series CA1 Obsolete Catalog Number	Series CA6 Equivalent Catalog Number
		kW (50 Hz)				UL/CSA HP (60 Hz)							
		AC-3	AC-1	230V	400V / 415V	500V	690V	1 Ø		3 Ø			
115V	230V							200V	230V	460V	575V		
115	250	37	64/66	80	111	10	25	40	40	75	100		CA6-115
						10	25	40	40	75	100	CA1-60	
140	250	45	78/82	80	111	15	30	40	50	100	125		CA6-140
						15	30	50	50	100	125	CA1-100	
180	250	57	101/105	98	135	~	40	50	60	150	150		CA6-180
						~	~	60	60	150	150	CA1-150	
210	350	67	118/122	147	205	~	50	60	75	150	200		CA6-210
						~	~	75	100	200	250	CA1-250	
250	350	80	140/145	177	250	~	~	75	100	200	250		CA6-250
300	450	97	170/176	213	293	~	~	100	125	250	300		CA6-300
						~	~	150	150	350	400	CA1-480	
420	500	135	238/250	298	424	~	~	150	175	350	400		CA6-420



CA1-10
Contactor

❶ Available auxiliary contacts may vary. See selection pages for more information.

Second Generation CEP7 Solid State Overload Relays

Advanced solid state motor protection

The introduction of the second generation of CEP7 solid state overload relays advances Sprecher + Schuh's leading edge technology with several improved features. This second generation of CEP7 overload relay includes features like:

- Selectable trip class and field installable modules
- A wider (5:1) set current adjustment range
- A more robust mechanical and electrical mounting
- Self-sealed latching mechanism

The basic concept of utilizing Application Specific Integrated Circuits (ASICs) resulting in an affordable solid state overload relays remains unchanged. This kind of versatility and accuracy was simply not possible with traditional bimetallic or eutectic alloy electromechanical overload relays.

Fewer units means greater application flexibility

The new CEP7 is available in three basic models:

- CEP7-ED1 is a Class 10, manual reset model available up to 27 amperes which covers the most common horsepower motors and your every day application. This model is economically priced to be competitive with adjustable bimetallic overload relays.
- CEP7-EE is full featured selectable trip class (10, 15, 20 & 30) 3-phase application overload relay with provision for field mountable modules to handle remote reset, stall and other modules previously available only in higher priced electronic overload relays. Manual reset or automatic reset can be selected with

dip switches on the new CEP7-EE models.

- CEP7S-EE is a 1-phase application overload relay packing all features of the 3-phase CEP7-EE model.

Wide current adjustment range

Thermal or bimetallic overload relays typically have a small current adjustment range of 1.5:1 meaning that the maximum setting is generally 1.5 times the lower setting. The first generation of CEP7 caused the industry to take note of the flexibility when it



introduced a 3.2:1 adjustment ratio. A wider adjustment range is the primary reason the industry has been turning to more specifications calling for electronic overload relay protection over thermal overload relays. Sprecher + Schuh building on field experience now introduces a CEP7 overload capable of adjustment to a maximum of five times the minimum set current which dramatically reduces the number of units required on-hand to cover the full range of current settings up to 90 amperes.



27A



45A



90A



30A

800A

5 : 1 Current Range

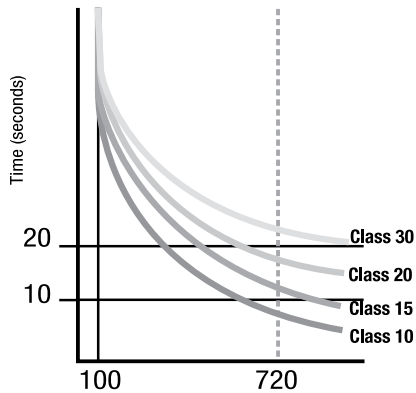

CEP7 overload relays are available with Class 10, 15, 20 or 30 tripping characteristics

Selectable tripping class

Because of today's lighter T-frame motors, Class 10 overload relays (relays that trip within 10 seconds of a locked rotor condition) have become the industry standard. If your application requires a longer motor run-up time. The new CEP7-EE Selectable Trip Class has DIP-switches providing Trip Class selection of 10, 15, 20 or 30 seconds. This ability allows you to closely match the Trip Class with the run-up time of the motor.

Choice of reset options

Most industrial applications usually calls for an overload relay that must be manually reset in the event of a trip.

This allows the cause of the overload to be identified before the motor is restarted. In specialized cases, however, such as rooftop AC units or where restarting the motor will not harm people or equipment, automatic reset may be desired. CEP7-ED1 overload relays are available with Manual Reset exclusively which keeps the cost down. CEP7-EE models have a selectable dip switch in Manual and Automatic Reset modes.

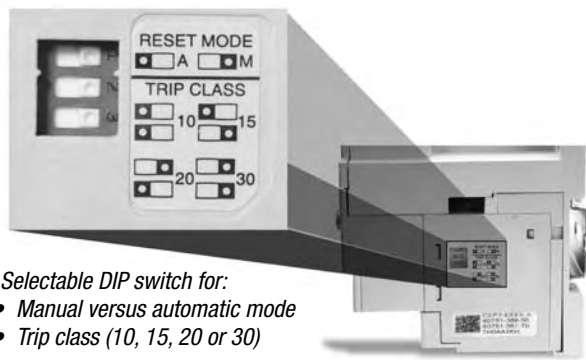

Selectable DIP switch for:
 • Manual versus automatic mode
 • Trip class (10, 15, 20 or 30)

potential environmental debris. The new CEP7 has been tested to operate in -20°C . or up to 60°C (140°F .) and withstand 3G of vibration or 30G of shock on a mountain up to an altitude of 2000m or in a jungle at 95% humidity. Reliability under every conceivable environmental condition is a quality built into the design of this second generation of CEP7 electronic overload relay.

Self-powered design means convenience

By developing the power it requires from the applied voltage, the CEP7 is "self-powered," eliminating the need for a separate control power source. This is not the case with some other competitive electronic overload relays. Since the CEP7 is self-powered and a traditional auxiliary contact is used to interface with the contactor, the user can apply the CEP7 the same way as an electromechanical overload. No special connections or control schematic diagram provisions are required in 3-phase applications.

Superior phase failure protection

The CEP7's on-board electronics are constantly monitoring all three phases. If the ASIC board senses that one phase is missing during a steady state running condition on a fully loaded motor, it will trigger in 3 seconds. If a single phase condition is present during starting, the CEP7 will trip within 8 seconds (for a motor >80% loaded). These times are much faster than any thermal bimetallic overload relay. In addition, CEP7 overload relays detect a 50% phase imbalance in the same way as a phase loss.

More robust design

The CEP7 has been re-designed to physically extend to the back-pan therefore aligning the mounting of the overload with the corresponding contactor. Further, the mechanical attachment and direct electrical connection to the contactor has been "beefed-up." This provides for a more robust mounting which means less damage from shipping or during field wire installation. The bipolar latching relay which controls the normally closed trip contacts and normally open alarm circuit contacts have been self-enclosed therefore insulating the electromagnet and shielding against airborne metal particles and other

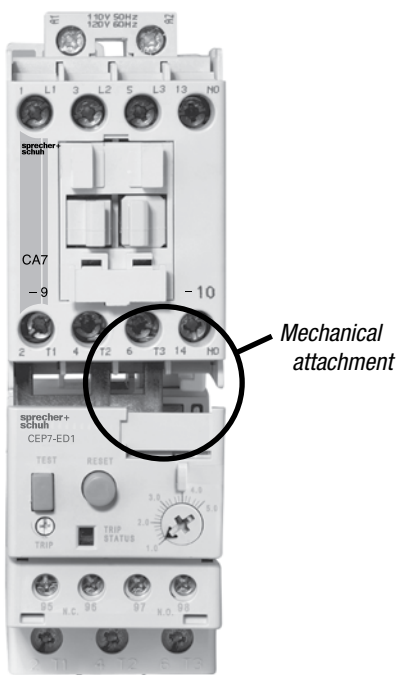



Increased accuracy and improved motor protection

Microelectronics provides flexible and accurate motor overload protection. Unlike traditional overload relays that simulate heat build-up in the motor by passing current through a heater element, CEP7 solid state overload relays measure motor current directly through integrated current transformers. The transformers, in turn, create a magnetic field that induces DC voltage onto the ASIC board. The electronics identify excessive current or loss of phase more accurately, and react to the condition with greater speed and reliability, than traditional overload relays. In addition, CEP7 solid state relays offer setting accuracies from 2.5 – 5% and repeat accuracy of 1%.

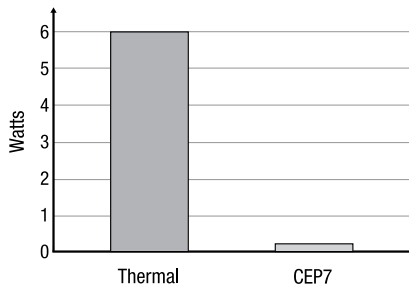

Conventional overload relays dissipate as much as six watts of energy compared with as little as 150 milliwatts for the CEP7

Dramatically lowered energy requirement saves money, reduces panel space

Because traditional overload relays work on the principle of “modeling” the heat generated in the motor (recreating the heat in the bimetal elements or heaters), a significant amount of energy is wasted. In traditional bimetallic overload relays, as many as six watts of heat are dissipated to perform the protective function. Because the CEP7 uses sampling techniques to actually measure the current flowing in the circuit, very little heat is dissipated in the device...as little as 150 milliwatts. This not only reduces the total amount of electrical energy consumed in an application, but it can also have a dramatic impact on the design and layout of control panels. The density of motor starters can be much greater because less heat is generated by each of the individual components. Higher density results in smaller control panels. In addition, special ventilation or air conditioning that might have been required to protect sensitive electronic equipment such as PLC’s can now be reduced or eliminated. CEP7 overload relays dramatically reduced energy requirement saves money and reduces panel space.



Additional Protection with Side Mount Modules



The CEP7 offers a variety of field installable accessories for side mount on the left side. Side mount modules provide additional motor protection functionality traditionally found only on more expensive models. Modules include the following additional features.

- **Remote Reset** provision for reset after trip from a remote pilot device
- **Jam Protection/Remote Reset** provides adjustable Jam set points and trip delay plus remote reset
- **Ground Fault Protection/Remote Reset** combined with ground fault current transformers provide adjustable set points for ground fault trip protection of equipment plus remote reset
- **Ground Fault/Jam Protection/Remote Reset** combines all three features as described above
- **PTC Thermistor Relay/Remote Reset** manages thermistor sensor signals from the motor
- **Network Communication Modules** provide motor diagnostic information via **Profibus** or **Ethernet** communication
 - Two discreet Inputs and one discreet Output
 - Differentiate between various motor protection algorithms
 - Overload and underload warning
 - Jam protection
 - Proactively alert maintenance personnel just before or when a fault occurs
 - Plus remote reset

Large Amp CEP7 Solid State Overload Relays, Automatic and Manual Reset ①②③④⑤

Overload Relay	Directly Mounts to Contactor... ②	CT Ratio	Adjustment Range (A)	Selectable Trip Class (10,15,20 & 30)
				Catalog Number
Automatic or Manual Reset for 3Ø Applications ①③				
 CEP7-EEHF	CA6-115...CA6-180 CA6-115-EI...CA6-180-EI CAN6-180(EI)	150:5	30...150	CEP7-EEHF
		200:5	40...200	CEP7-EEJF
	CA6-210-EI...CA6-420-EI CAN6-300-EI	200:5	40...200	CEP7-EEJG
		300:5	60...300	CEP7-EEKG
	CA6-630-EI...CA6-860-EI	500:5	100...500	CEP7-EELG
		600:5	120...600	CEP7-EEMH
800:5	160...800	CEP7-EENH		

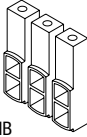
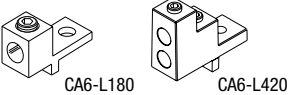
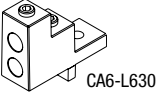
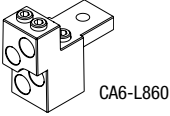
Load Side Lugs & Accessories

Lug or Accessory	Description	For Use With...	Catalog Number
 CA6-HB	Main Terminal Set, ⑤ Dual Conductor, Touch Safe <ul style="list-style-type: none"> Accommodation for dual connections to each pole Accepts flat or round conductors Touch safe to IP20 according to IEC 60529 Eliminates need for Terminal Shields (price as complete set, containing 2 blocks, 6 lugs) 	CEP7-EEHF CEP7-EEJF	CA6-HB2
		CEP7-EEJG CEP7-EEKG CEP7-EELG	CA6-HB3
 CA6-L180 CA6-L420	Screw Type Lugs - <ul style="list-style-type: none"> Accepts round conductors only Copper construction (set of 3 lugs) 	CEP7-EEHF CEP7-EEJF	CA6-L180
		CEP7-EEJG CEP7-EEKG CEP7-EELG	CA6-L420
 CA6-L630	Screw Type Lugs - <ul style="list-style-type: none"> Accommodation for dual connections to each pole Copper construction accepts round conductors only (set of 3 lugs) 	CEP7-EEMH CEP7-EENH	CA6-L630
 CA6-L860	Screw Type Lugs - <ul style="list-style-type: none"> Accommodation for dual connections to each pole Copper construction accepts round conductors only (set of 3 lugs) 	CEP7-EEMH CEP7-EENH	CA6-L860
	Main Terminal Cover - ⑥ <ul style="list-style-type: none"> CA6 touch protection Line or load (price each) IP20; IEC60529 & DIN 40 050 protection 	CA6-115(-EI) to 180(-EI) CA6-210-EI to 420-EI CA6-630-EI to 860-EI	CA6-TC180 CA6-TC420 CA6-TC860

① 3-phase CEP7 units are only designed for 3Ø applications.

② This reference is not intended to be a guide for selecting contactors. Size overload relays using the full load current of the motor.

③ The reset time of a CEP7 set in the automatic mode is approximately 180 seconds.

④ CEP7 Overload relays do not work with Variable Frequency Drives or any Sprecher + Schuh Softstarter with braking options.

⑤ Terminal covers not necessary when using CA6-HB-__ insulated lugs.

⑥ CEP7-EEHF...CEP7-EENH include current transformers used to monitor high amperage.

CEP7 Current Transformer Models mounted to CA6 Contactor

Dimensions are in millimeters (inches). Dimensions not intended for manufacturing purposes.

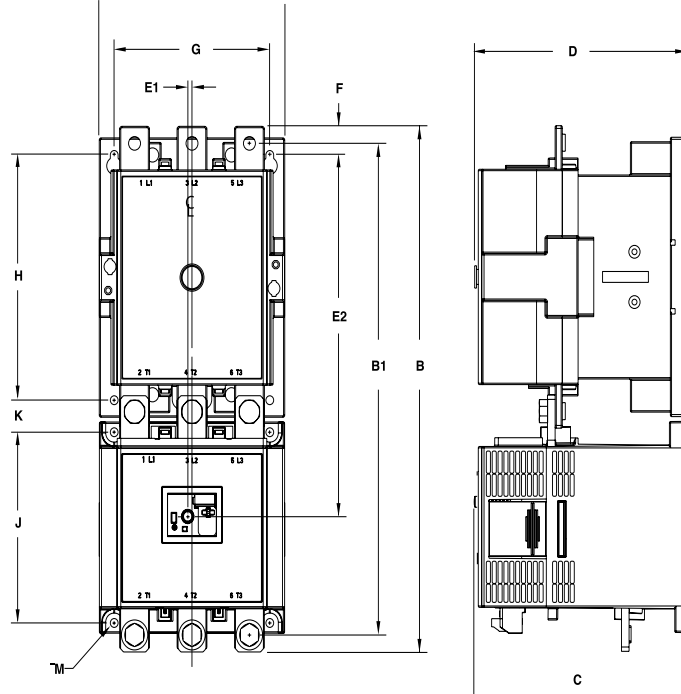

Overload Relay Cat.	Contactor Cat.	A Width	B Height		B1	C Depth Reset	D	E1	E2	F	G	H	J	K	M
			Without Terminal Covers	With Terminal Covers											
CEP7-EEHF CEP7-EEJF	CA6-115 (EI)	120 (4.72)	339.8	418	317.8	152.7	156	36	226.3	16	100	145	135	22.3	8 - 5.6
	CA6-140 (EI)		13.38	16.46	12.51	6.01	6.14	.14	8.91	.63	3.94	5.71	5.31	.88	8 - .22
	CA6-180 (EI)														
CEP7-EE_G	CA6-210 EI	155 (6.10)	385.8	487.4	360.8	176.5	180	36	265.5	21	130	180	140	23.5	8 - 6.5
	CA6-300-EI		15.19	19.19	14.2	6.95	7.09	.14	10.44	.83	5.12	7.09	5.51	.93	8 - .26
	CA6-420 EI														
CEP7-EE_H	CA6-630 EI	255 (10.04)	552	915	508	269.3	270.7	36	384.1	52.5	226	230	108	109	8 - 13
	CA6-860 EI		21.73	36.02	20	10.6	10.66	.14	15.12	2.07	8.90	9.06	4.25	4.29	8 - .51

Assembly Instructions

- CEP7-EE_F: (M5)
3.4 N m (30 lb-in)
- CEP7-EE_G: (M6)
5.1 N m (45 lb-in)
- CEP7-EE_H: (M12 Provided)
17 N m (150 lb-in)

